

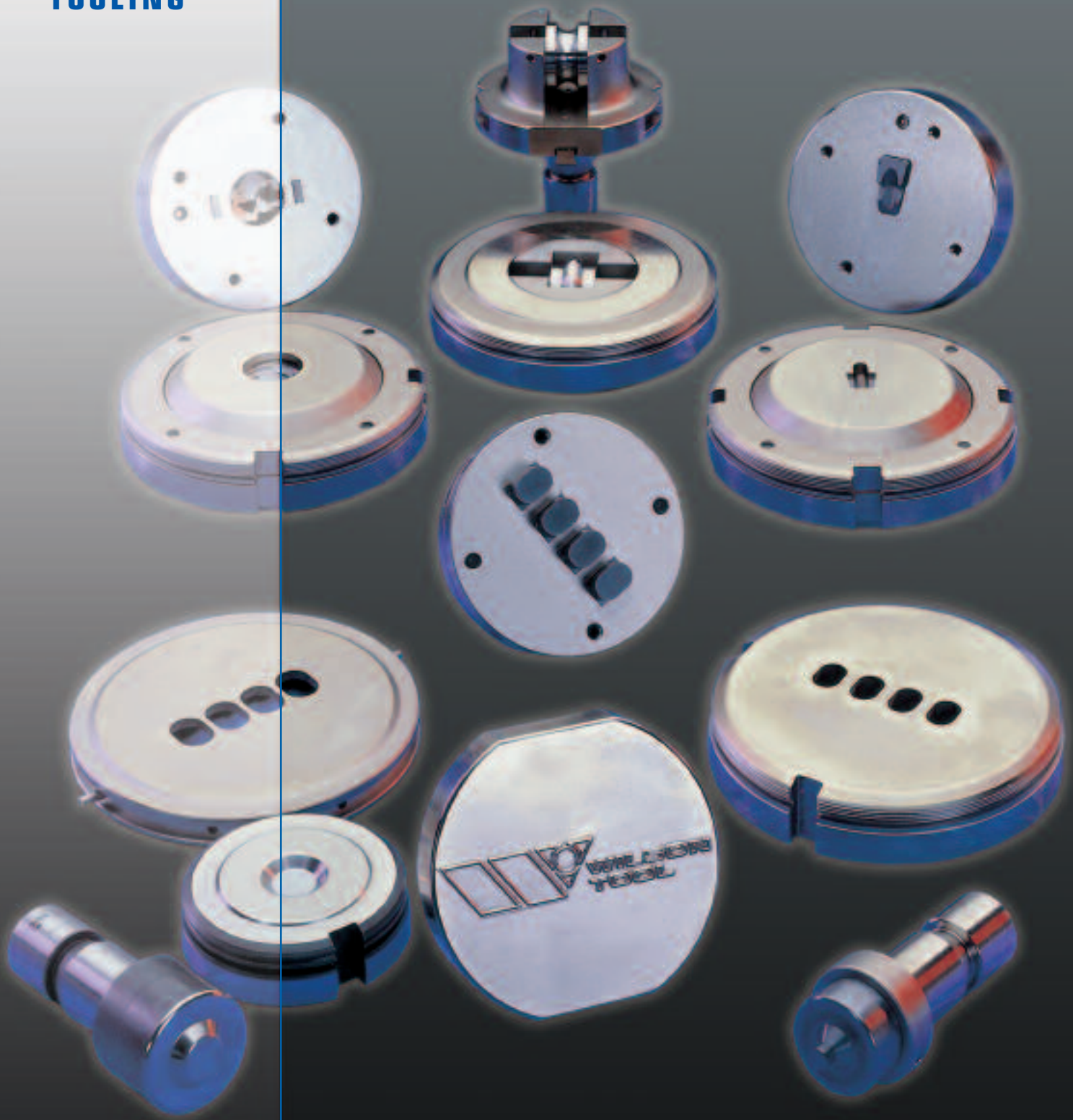

**TRUMPF-STYLE  
SPECIAL  
TOOLING**



*Strength. Performance. Innovation.*

<b>Contents</b>	<b>Page Number</b>
Trumpf Machine Groups	2
Special Shapes	3
Cluster Tool	13
Emboss Forming Tools, Form-Up	14
Emboss Forming Tools, Form-Down	15
Lance and Forms, Form-Up	16
Zip-Tech Special Lance and Form Tools	17
Half Shear, Form-Up	18
Rooftop Half Shear, Form-Up	18
Coining Countersink/Counterbore Tools (Solid Style)	19
Coining Form-Up/Form-Down (Replaceable Insert Style)	20
Extrusion Tools	21
Electrical Knockouts, Form-Up and Form-Down	22
Louvres, Form-Up	23
Progressive Louvres, Form-Up	24
Louvres, Form-Down	25
Bridge Type Lance and Forms, Form-Up	26
Card Guides, Form-Up	27
Progressive Ribs	28
Hinge Tool, Form-Up	29
Hand Hold Tool, Form-Up	30
Dash Tool/Earth Symbol	31
Letter Stamps and Logos	32
Wilson Wheel® Family	33
One Hit Hinge	34
A Plus Series Tooling	35
Large Diameter Hole: Trumpf-Style Machines with Rotation	36
Large Diameter Hole: Trumpf-Style Non-Rotation Machines	37

**Trumpf Machine Groups**

A	B	C	D	E	F	G	H	I	S	
CN 700	CN 901E	CN 1200S	Trumatic	Sunimat 400		Trumatic	Trumatic	Trumatic	Trumatic	Minimatic
CN 900	CN 902	CN 1200a	20	Trumatic	Trumatic	150W	20aW	190R	1000R	100
CN 701	CS 75	CS 15	20a	150K	202K	152W	202W	200R	2000R	Trumatic
CN 901	CS 75.2	CS 20	202M	151K	225K	180W	300W	500R	2010R	120R
		CS 20a		152K	235K	180.2W	300LW	600L	2020R	160R
		MP 25		180K	300K	180R	300PW		5000R	
		MP 25D		180.2K	300LK	180LW	300top		6000L	
				180KD	300PK	180.2LW	400W		3000R	
				180LK	400K	ELX/SWIFT				
				180.2LK		185				
						240				
						240R				
						250				
						260R				

## Group "A" Special Shapes

Note: Special considerations may alter price and lead time.

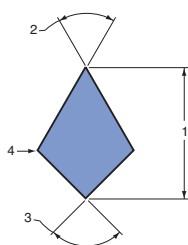

S1

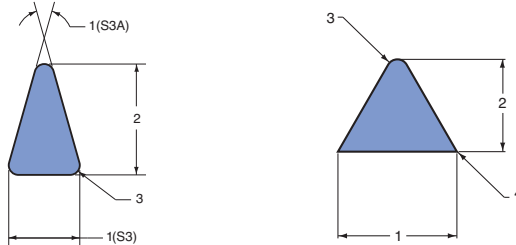

S3 -S3A

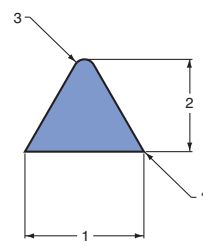

S4

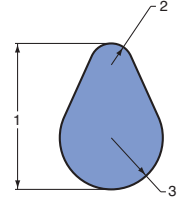

S7

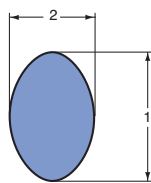

S8

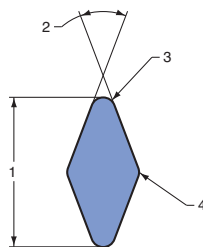

S9

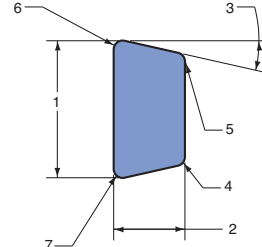

S23

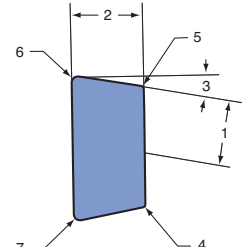

S23A

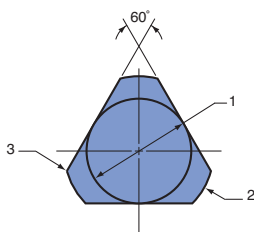

S50

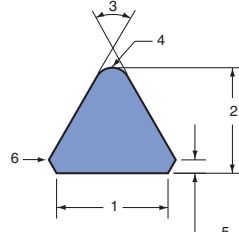

S51

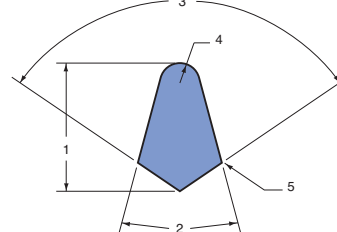

S59

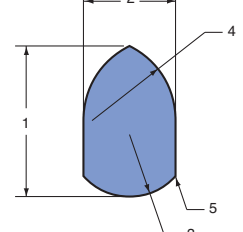

S65

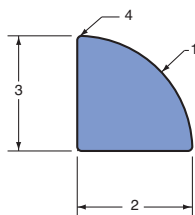

S69

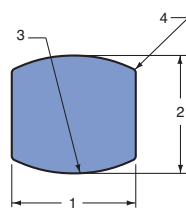

S81

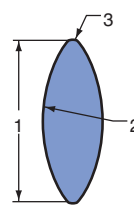

S95L

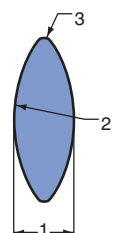

S95W

# Group "A" Special Shapes

Note: Special considerations may alter price and lead time.

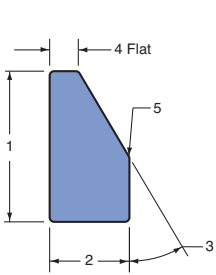

**S97**

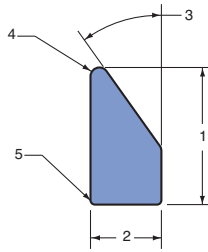

**S100**

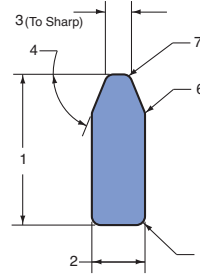

**S102**

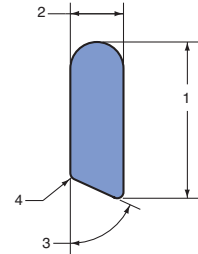

**S103**

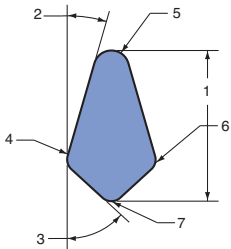

**S105**

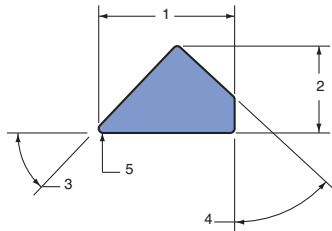

**S106**

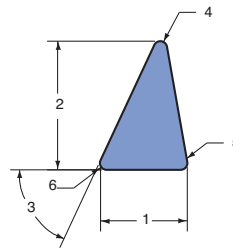

**S108**

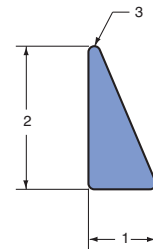

**S109**

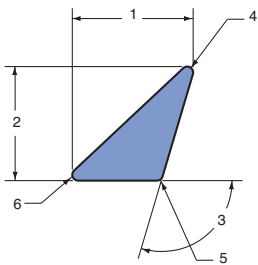

**S110**

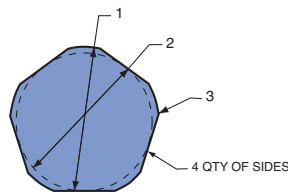

**S121**

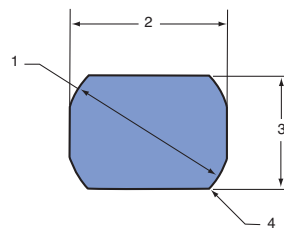

**S122**

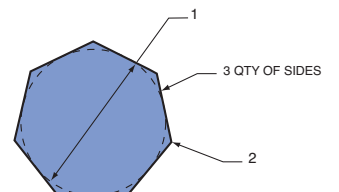

**S123**

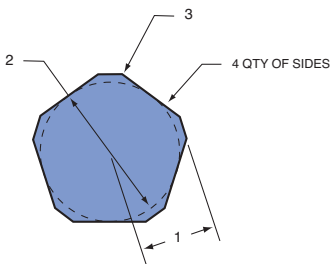

**S124**

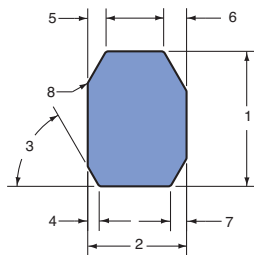

**S161**

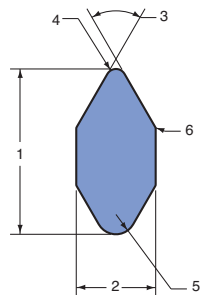

**S162**

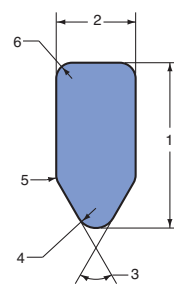

**S163**

## Group "A" Special Shapes

Note: Special considerations may alter price and lead time.

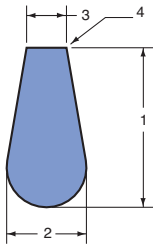

**S164**

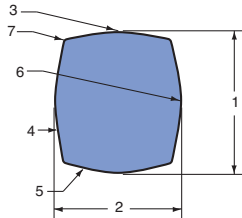

**S165**

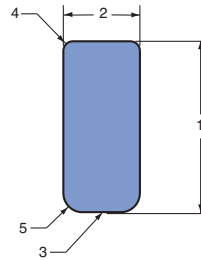

**S166**

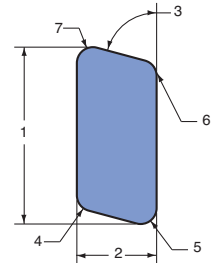

**S167**

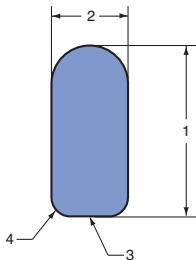

**S170**

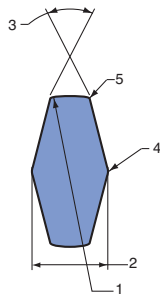

**S181**

## Group "B" Special Shapes

Note: Special considerations may alter price and lead time.

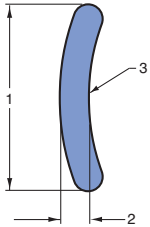

**S6**

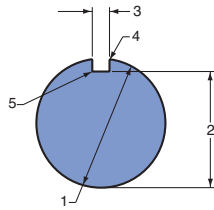

**S10**

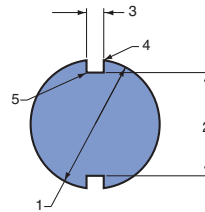

**S11**

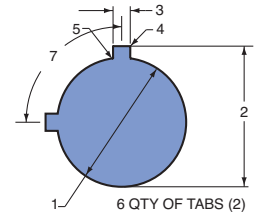

**S12**

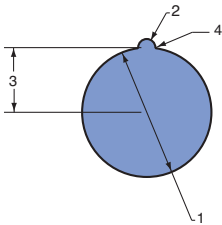

**S13**

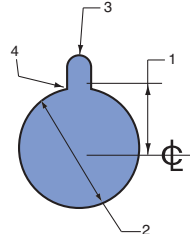

**S14**

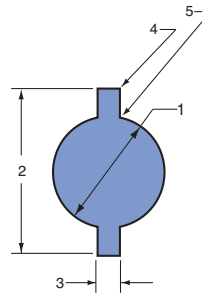

**S15**

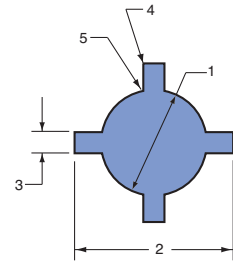

**S16**

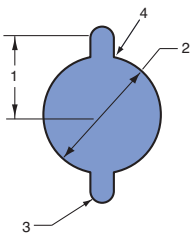

**S17**

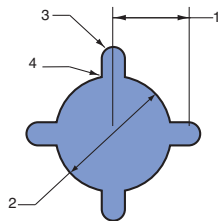

**S18**

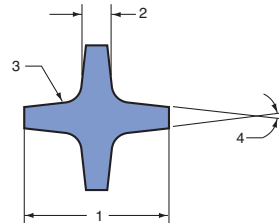

**S19**

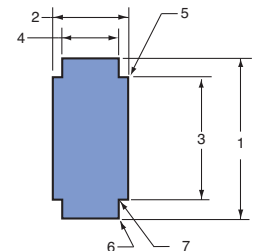

**S20**

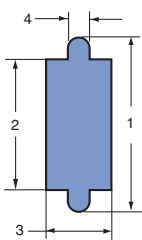

**S21**

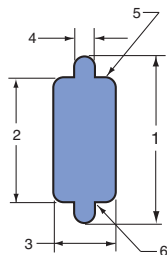

**S22**

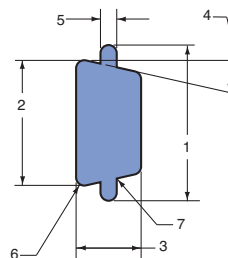

**S24**

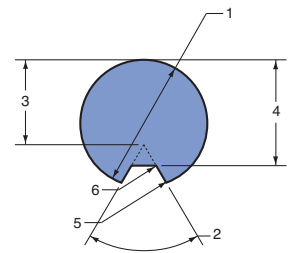

**S30**

## Group "B" Special Shapes

Note: Special considerations may alter price and lead time.

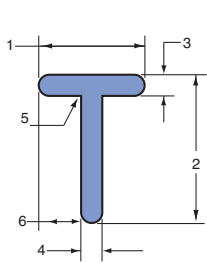

S31

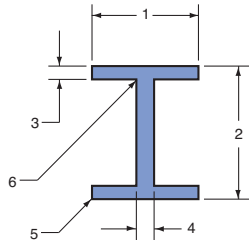

S33

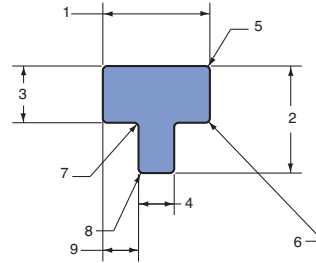

S35

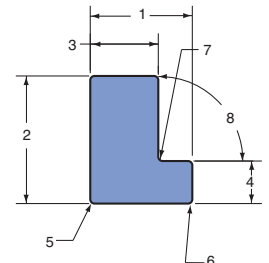

S36

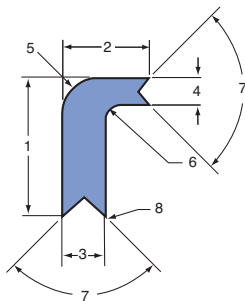

S37

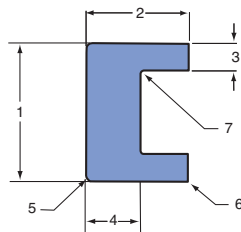

S40

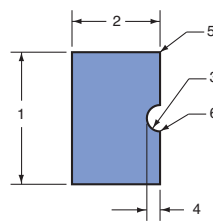

S41

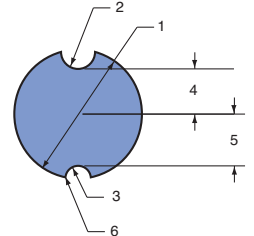

S42

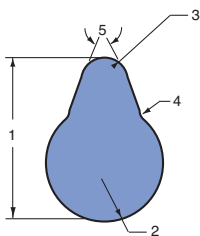

S43

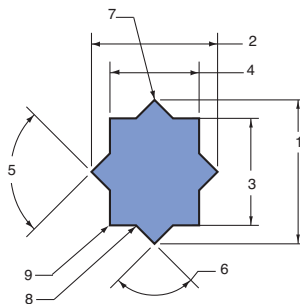

S46

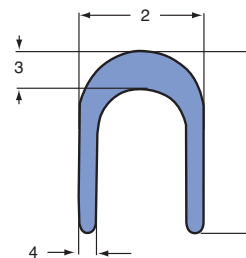

S54

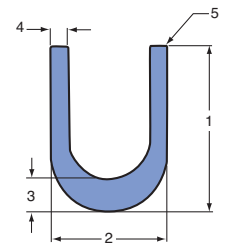

S55

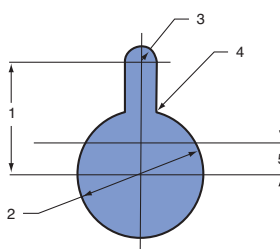

S56

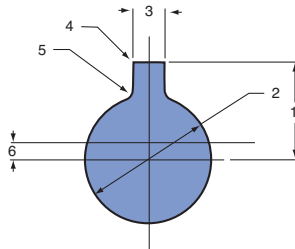

S57

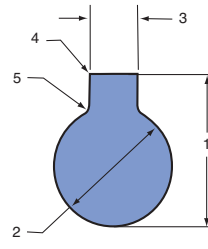

S58

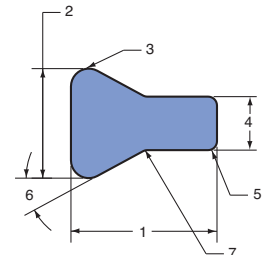

S60



## Group "B" Special Shapes

Note: Special considerations may alter price and lead time.

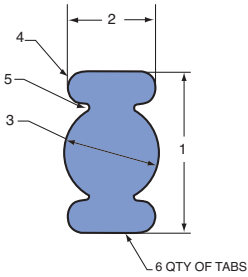

S61

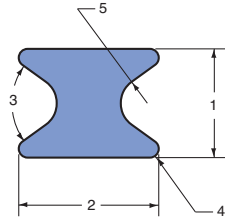

S62

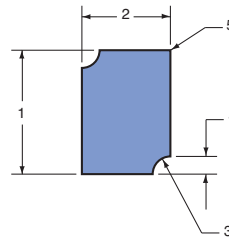

S66

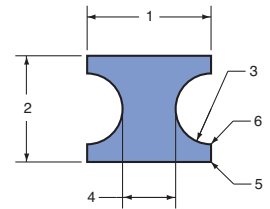

S79

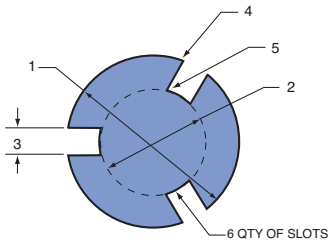

S82

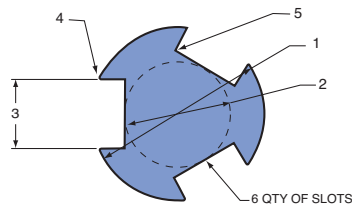

S83

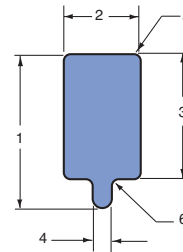

S84

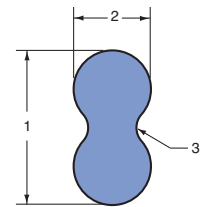

S87

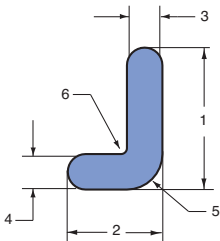

S88

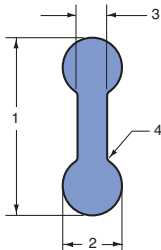

S91

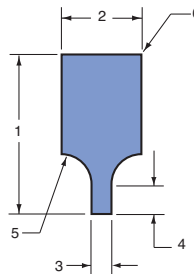

S93

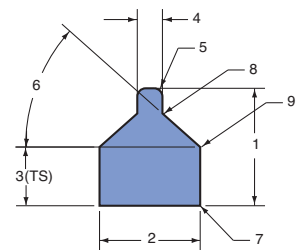

S114

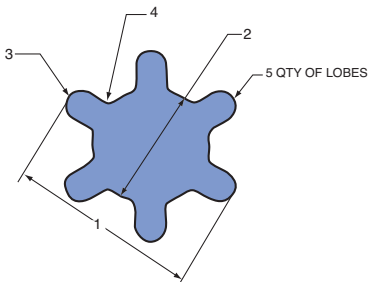

S115

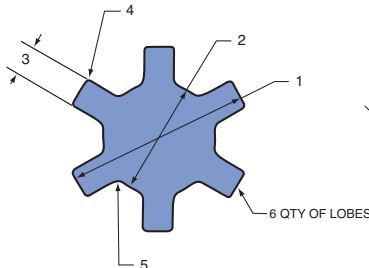

S116

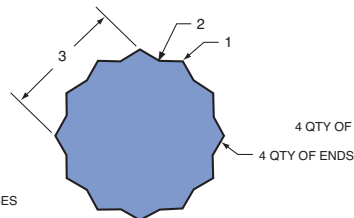

S117

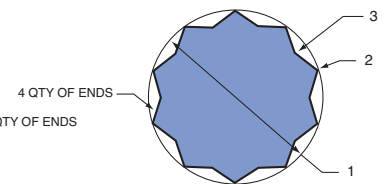

S118

# Group "B" Special Shapes

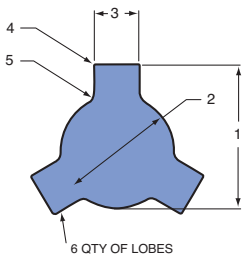

S119

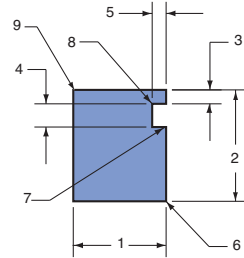

S120

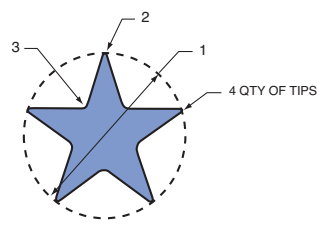

S125

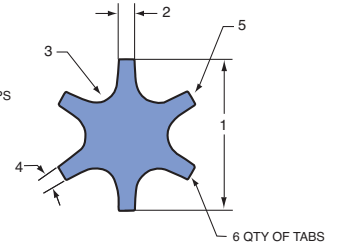

S126

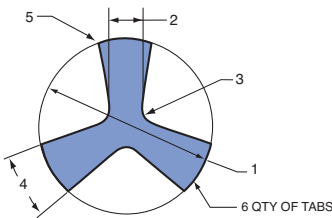

S127

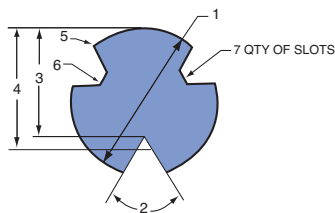

S128

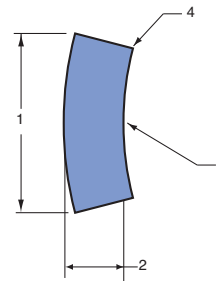

S141

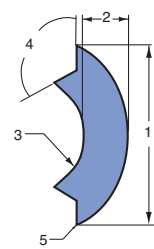

S142

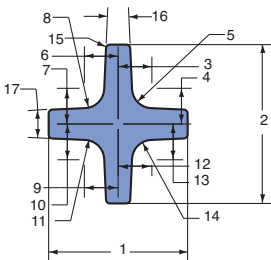

S168

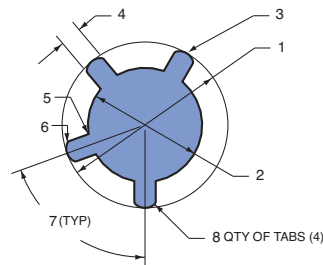

S169

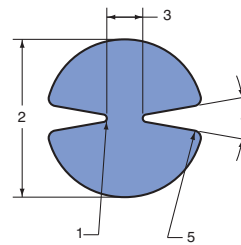

S171

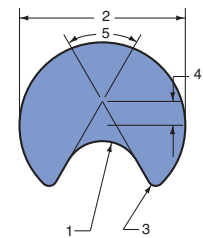

S172

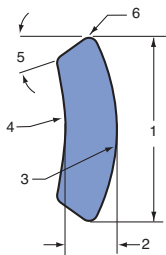

S174

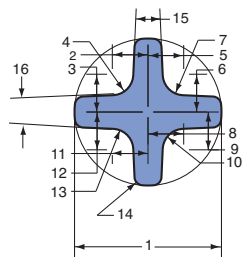

S176

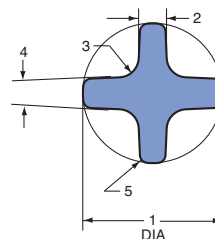

S177

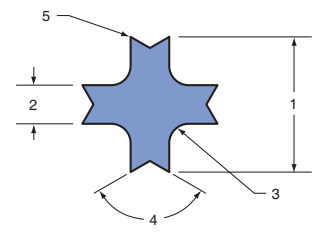

S179

## Group "B" Special Shapes

Note: Special considerations may alter price and lead time.

4 way Radius Tools - stock sizes					
Stock sizes Group A (Non-stock Sizes Group B)					
Dimension 1		Dimension 2		Radius Dimension 3	
11mm		5mm		3mm	
13mm		5mm		4mm	
15mm		5mm		5mm	
17mm		5mm		6mm	
Clearances for Trumpf tooling (mm)					
0.2	0.3	0.4	0.5	0.6	

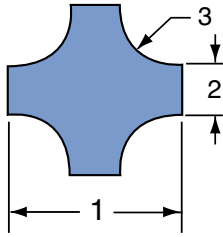

## Group "C" Special Shapes

Note: Special considerations may alter price and lead time.

The following are just a few shapes representative of the "C" Group. If you do not see a shape similar to yours, fax a drawing to our Sales Desk.

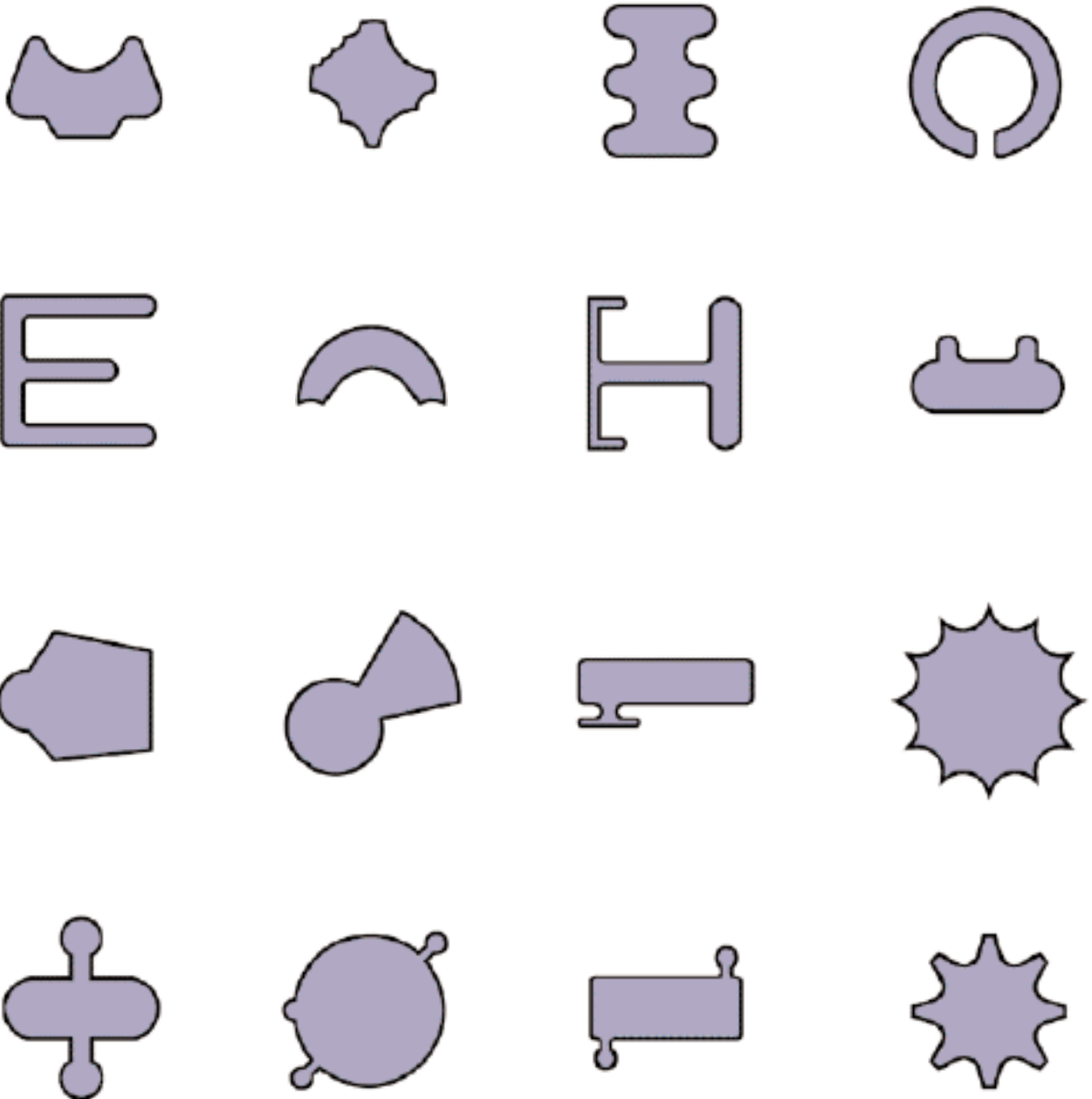

## Group "C" Special Shapes

Note: Special considerations may alter price and lead time.

The following are just a few shapes representative of the "C" Group. If you do not see a shape similar to yours, fax a drawing to our Sales Desk.

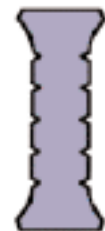
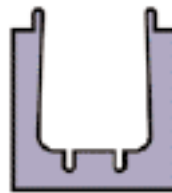
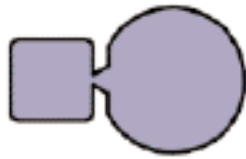
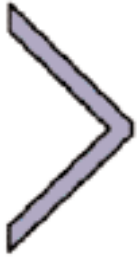

## Clusters

Clusters can be designed with as few as two holes or as many as 120 holes or more, depending on your application and design. Clusters are many times the most cost efficient method of manufacture, in perforations or other repetitive applications. The cluster will save on machine punching time and tool maintenance time. When punching a particular pattern of holes that requires extremely close centre tolerances, the cluster tool is the best choice. Putting these holes in the same cluster will eliminate the machine tolerancing of hole-to-hole punching. Wilson Tool designs these clusters with the customer in mind. As you may notice in the different styles of cluster offered, we usually prefer to use replaceable inserts so that the operational costs of the tool are reduced for you. These clusters are precision machined and ground, not just milled.

## Information needed:

- How many hole clusters
- Straight or staggered pattern
- Centre to centre dimensions
- Material thickness and type
- A, B, or C style desired
- Machine model

**To ensure accurate punch alignment, cluster tools with standard stripping have integral collars. Size 2 clusters with integral stripping in the punch also have integral collars.**

## Limitations

- Round holes must have a web between holes of 3mm or 2 times material thickness, whichever is greater, to warranty the die.
- Long and narrow shapes must have a web between holes:
  - Up to 12.5mm length – 3.0mm or 2 times material thickness, whichever is greater
  - 12.51mm to 25.5mm length – 4.0mm or 2 times material thickness, whichever is greater
  - 25.51mm to 51mm length – 6.5mm or 2 times material thickness, whichever is greater
  - 51.1mm – up length – 8.0mm or 2 times material thickness, whichever is greater

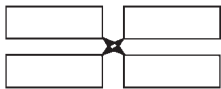

*Cross-Stress*

Cannot follow above guidelines for warranty.  
Warranty to be determined per application.

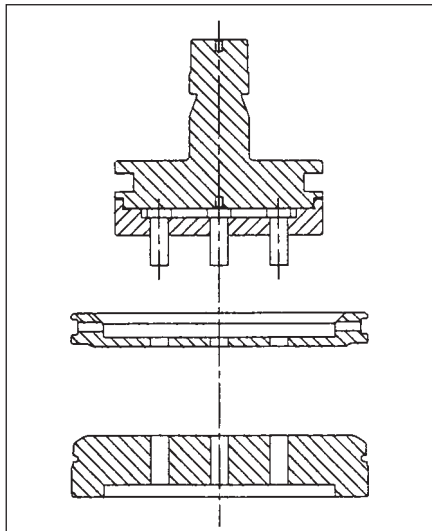

**Style "A" Standard Stripping**

In this cluster design the punch tips are replaceable. This enables punch tips to be replaced economically. It also utilises a standard stripper, which allows faster punching speeds in operation.

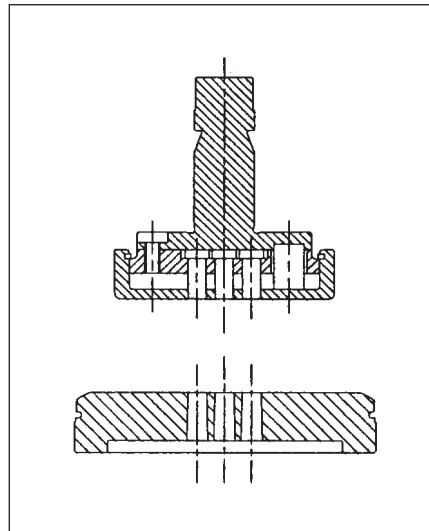

**Style "B" Self Stripping**

This is recommended for thin materials. The design is similar to the Style "A", utilising insert punches for economic replacement, but with its close stripping system mounted directly onto the punch it is ideally suited to be used with thin materials which pose problems with stripping.

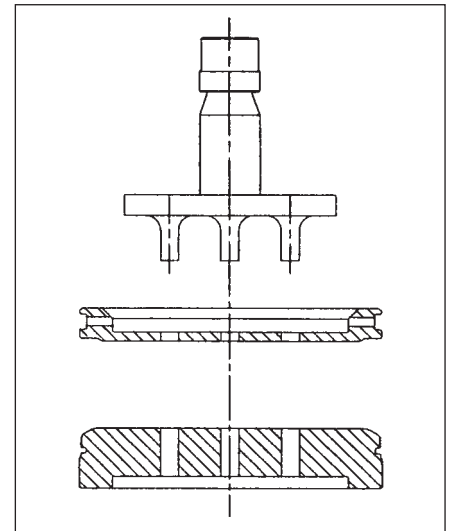

**Style "C" Solid Punch**

This style is least popular even though it may be least expensive. If damage to one or more punch tips does occur, a complete replacement cluster punch must be supplied, not just a single insert as with the "A" and "B" styles. However, there are particular shapes or sizes that mean this is the only type possible.

## Sharpening

- Small quill punches need to be supported while grinding. If not supported the vibrations caused by grinding will break the quills. Use rubber bands or a piece of punched plastic sheet to retard vibration.
- Always grind shaped punches the long way. Use vibration control methods as listed above.



These emboss-style forming tools are useful for stand-offs, spacers, large countersinks, and locking for nuts. With our variety of expertise in design, we can tailor the correct tool for your application.

### Information needed:

- Full dimensioning (height, dia. or shape, angle, radius, through hole, etc.)
- Drawing if possible
- Material thickness
- Machine model
- Dimensions preferred to a theoretical sharp

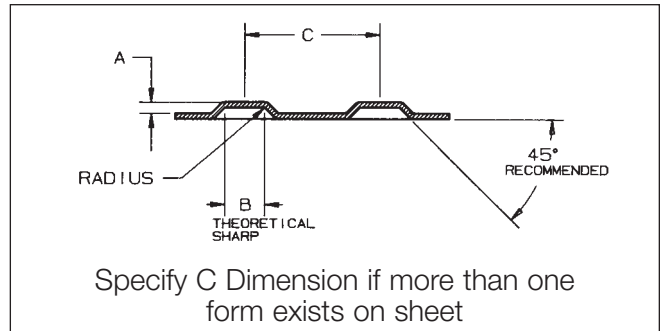

Tool Type	Description	Cat. No.
Size I	With Stripping	25176
Size I	Without Stripping	25194
Size II	With Stripping	25195
Size II	Without Stripping	25143
Size III	With Stripping	25620
Size III	Without Stripping	25645

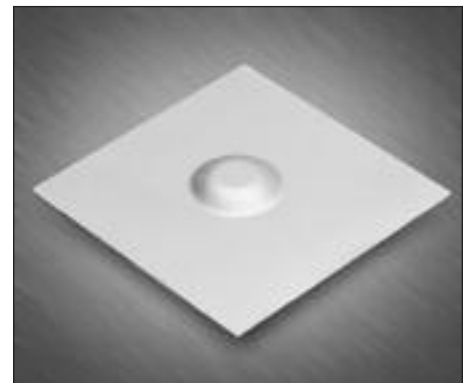

### Design criteria:

- Keep forming tools as far from clamps and pierced holes as possible.
- If you are having stripping problems or your form is not coming out, make sure you are "bottoming out".
- A ring mark around the form indicates stroking too deep.
- A 45° angle is recommended on forming tools.
- For maximum size in different stations consult Sales Desk.
- Never punch material thicker than the tool was designed for.

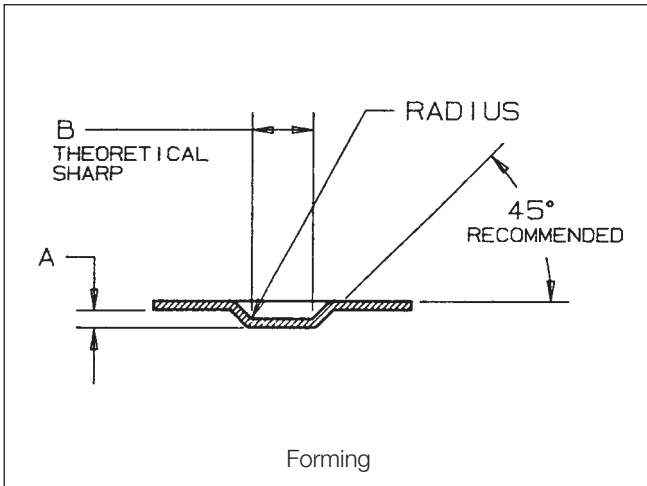

### Information needed:

- Full dimensioning of form
- Drawing if possible
- Material thickness
- Machine model
- Dimensions preferred to a theoretical sharp

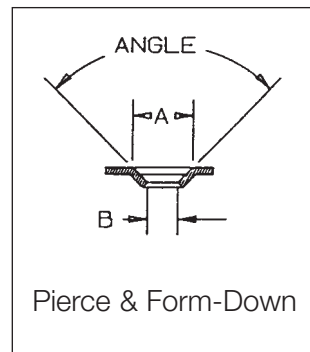

Tool Type	Description	Cat. No.
Size I	Without Stripping	25353
Size II	Without Stripping	25174
Size II	With Stripping	25191
Size III	Without Stripping	25647
Size III	With Stripping	25646

### Design criteria:

- May be possible to pierce and form in one operation. (consult Sales Desk with your application).



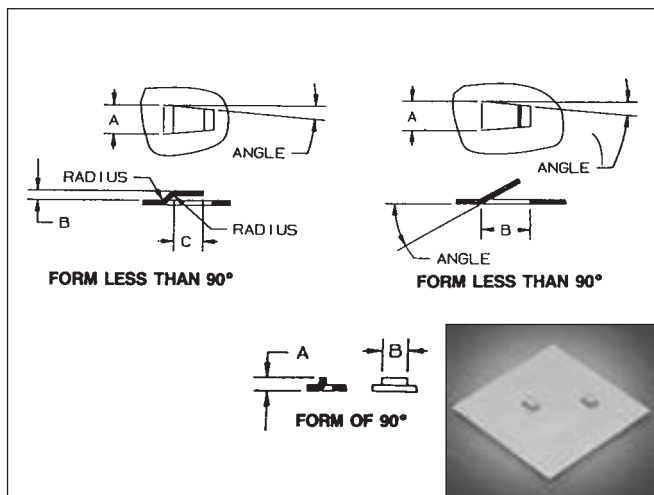

### Information needed:

- Complete drawings of the Lance and Form showing length, width, height, material thickness and type, angles, and other forms (if any) near the Lance and Form so proper relief can be built into the tool
- Machine model

Lance and Forms are used in many applications such as for air flow, decoration, card guides, location markers, shear tabs, wire harnesses, clip attachments . . . these are very useful tools.

Lance and Form less than 90°		Lance and Form of 90°	
Group S	25650	Group S	25642
Size II	25133	Size II	25643
Size III	25641	Size III	25644

## VARIATIONS

Special bend Lance and Forms (Prices on application)

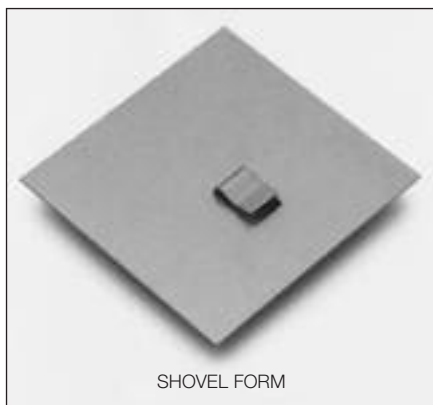

### Design criteria:

- Consult Sales Desk for size and height restrictions per station.
- In some cases, you must prepunch around the tab on Lance and Forms of 90° when punching aluminium.
- Lance and Forms are made for a particular material thickness. Never run thicker material or damage will occur. You can adjust the tool to run lighter material but the form will change.
- Consult Sales Desk for special shaped Lance and Forms.
- Lance and Forms of 90° must form a minimum of 2 material thicknesses overall.
- Maximum material thickness for Lance and Forms is 3.0mm. Consult Sales Desk for special applications.
- On Lance and Forms of less than 90°, a taper of 5° per side should be added to aid in stripping.
- Form-Down Lance and Forms are not recommended for N/C machines.



Description
Size II Zip-Tech™ Tool P&D Assy Complete Set
Size II Zip-Tech™ Punch Assy (less holder) W/Die Assy
Size II Zip-Tech™ Punch Tip Only
Size II Zip-Tech™ Punch Ejector Only
Size II Zip-Tech™ Punch Piercing Insert Only
Size II Zip-Tech™ Die Assy Only
Size II Zip-Tech™ Die Insert Only

## Design Criteria:

- Two special tools are required; One is a simple “T” shape to punch around the full radius tabs, and the second is a special Lance and Form/Up with Half-Shear Down (see above). Both tools need to be used with a Rotation machine.
- Price the “T” shape from our B group price list in Size I.
- A standard round tool is also required, 2.04mm diameter.
- The special Lance Tool is material specific; a separate tool is needed for each material thickness.
- Consult Sales Desk for limitations.
- Zip-Tech can be made to work on any style of tooling.
- The tool can work in stainless, mild steel and in aluminium. In fact you can join two different types of material together as long as they are the same thickness of material.
- The holding strength of this fastening method can be difficult to determine and depends on the condition of the tool and the machine. It is similar to the same strength that you would have in a spot weld.

# TRUMPF-STYLE Form-Up Half Shear/Rooftop Half Shear

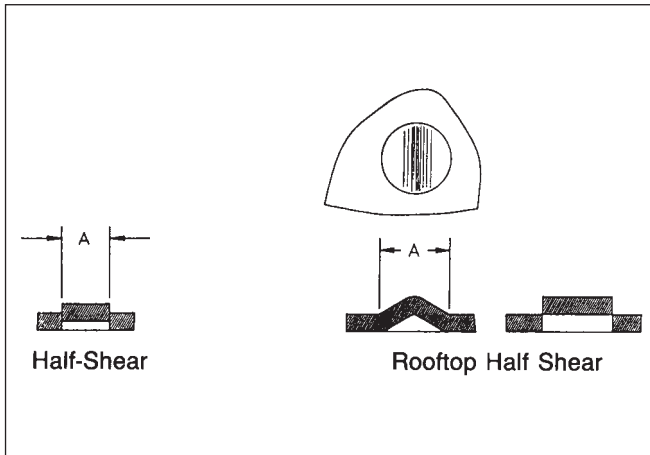

## Information needed:

- Diameter or shape (on top of sheet)
- Material thickness and type (or range)
- Machine model

This handy tool, which is easy to use, allows you to put in shear buttons and spot welding locations to the accuracy of your punch press. Because of the round design it is an excellent locator for angle shearing.

The rooftop half shear is sometimes preferred because of its increased protrusion from the metal. This aids in picking up the locator on the sheet.

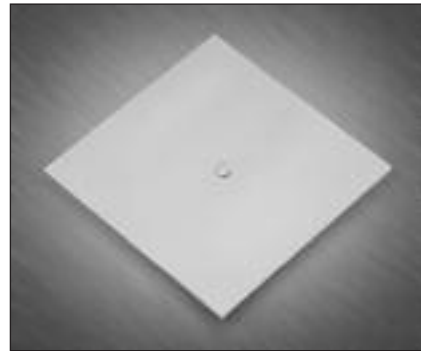

## HALF SHEAR

Tool Type	Size	Cat. No.
Form-Up	Size I – 6mm max. diameter	25120
Form-Up	Size II – 6.01 – 20mm max. diameter	25367
Form-Down		25631

## ROOFTOP HALF SHEAR

Tool Type	Size	Cat. No.
Form-Up	Size I	25640

## Design criteria: Half Shear

- Half Shears work best in thicker material (more material to grab the button).
- On material thickness less than 1.2mm it is recommended that a holding tab be put on the half shear to hold the button (similar to the electrical knockout).
- Never punch material thicker than the tool was designed for.

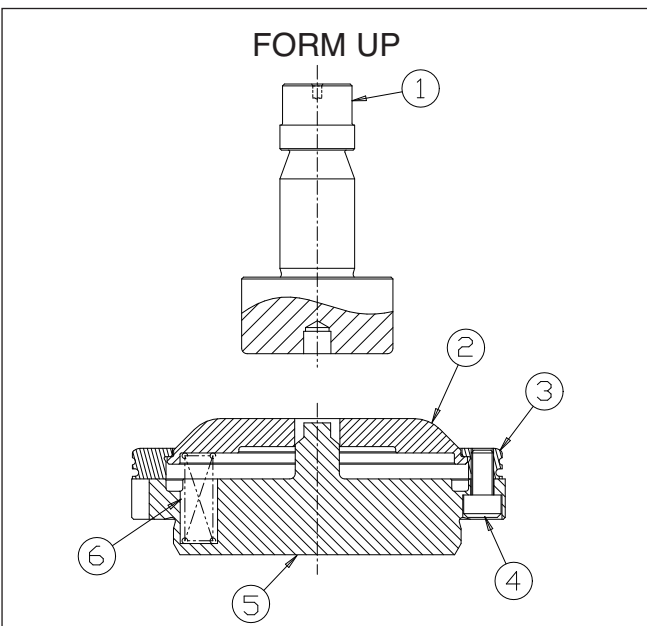
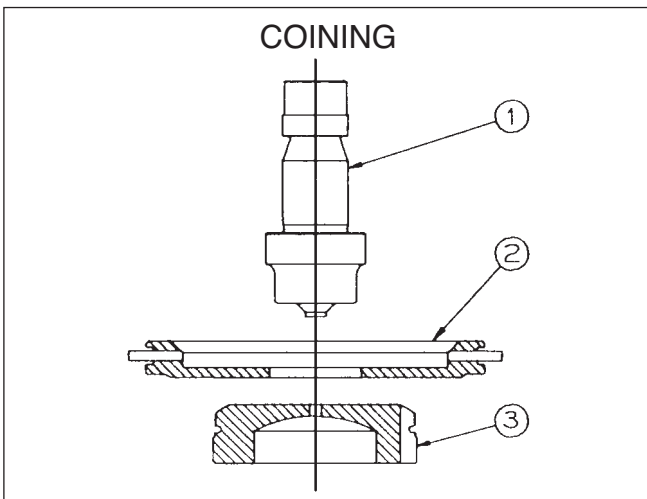
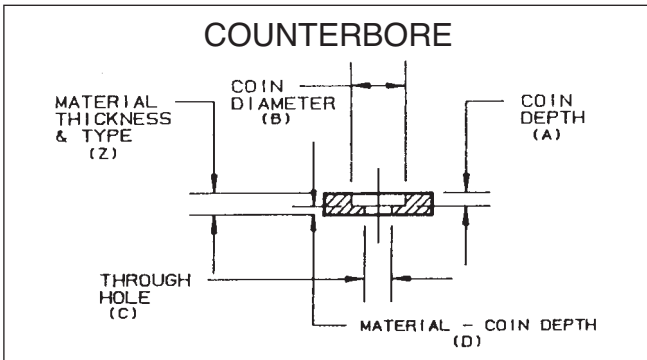
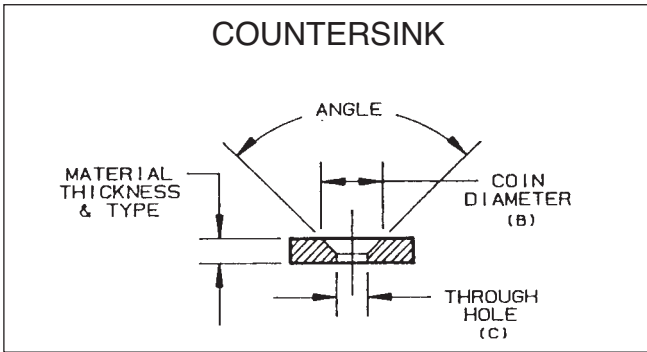

A coining operation on the punch press is once again a money-saving operation which eliminates a secondary operation. In the case of countersinking, the time saved in punching versus drilling is substantial, whilst also resulting in a superior product.

### Information needed:

- Angle, coin diameter, coin depth or through-hole, or screw size and head type
- Material thickness and type
- With or without pilot
- Machine model

### Design criteria:

- Recommended for countersink/coining above 3.0mm material thickness
- All counterbore coining must be Solid Style
- Formula for estimated prepunch of countersink/coining:  $B - [(B - C) \times .75] = \text{Prepunch}$
- Formula for estimated prepunch of counterbore coining:  $\frac{(A \times B) + (C \times D)}{Z} = \text{Prepunch}$
- Aluminium will leave more of a burr on the bottom of the sheet than mild steel or stainless steel

### FORM DOWN

Description	Cat. No.
1. Punch (countersink)	25115
Punch (counterbore)	25323
2. Stripper	25006
3. Round Die	25005

### FORM UP

Description	Cat. No.
Complete Tool	25565
1. Punch	25565-1
2. Die Cap	
3. Retaining Ring	26074
4. Screw (4 Required)	30159
5. Die Base	25565-8
6. Spring (8 Required)	25285

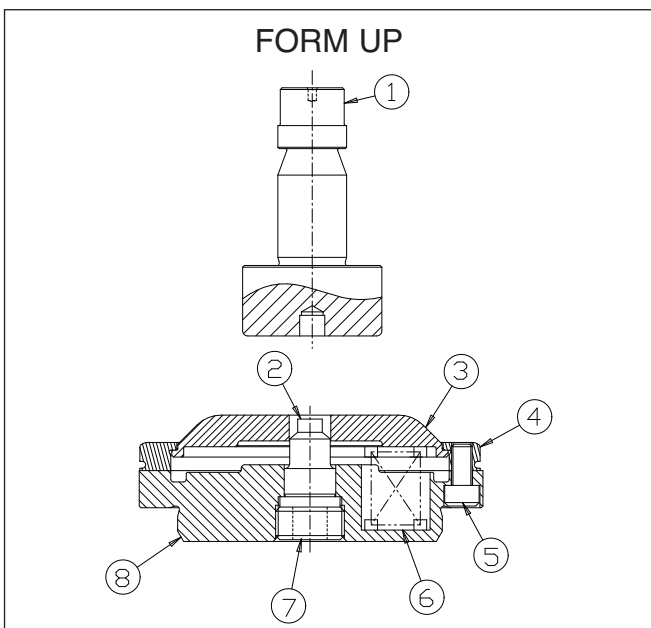
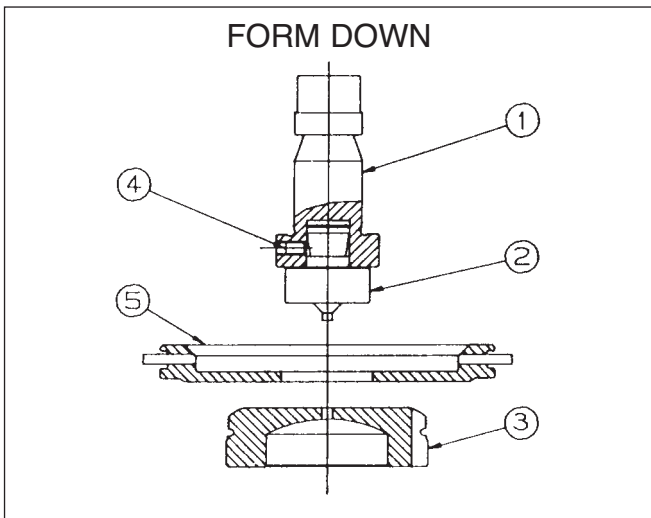
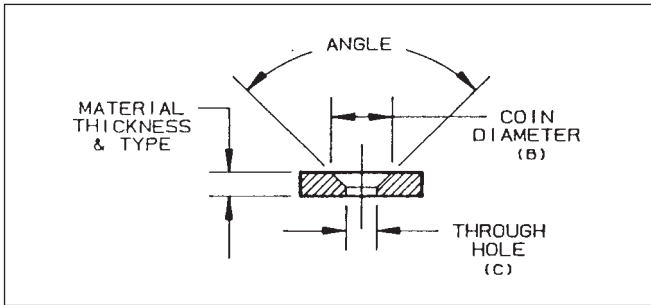

A coining operation on the punch press is once again a money-saving operation which eliminates a secondary operation. In the case of countersinking, the time saved in punching versus drilling is substantial, whilst also resulting in a superior product.

### Information needed:

- Angle, coin diameter and through-hole, or screw size and head type
- Material thickness and type
- With or without pilot
- Machine model

### Design criteria:

- 3.0mm maximum material thickness
- Coining tool must always be prepunched
- Formula for estimated prepunch hole size:  
 $B - [(B - C) \times .75] = \text{Prepunch}$
- Aluminium will leave more of a burr on the sheet than mild steel or stainless steel

### FORM DOWN

Description	Cat. No.
Complete Tool	25331
1. Insert Holder	25221-1
2. Insert (with pilot)	25331-2A
Insert (without pilot)	25331-2B
3. Round Die	*
4. Screw	25246
5. Round Stripper	25006

\*Depending on coin size

### FORM UP

Description	Cat. No.
Complete Tool	25565
1. Punch	25565-1
2. Die Insert	25565-7
3. Die Cap	
4. Retaining Ring	26074
5. Screw (4 Required)	30159
6. Spring (6 Required)	25279
7. Jam Screw	6930
8. Die Base	26068

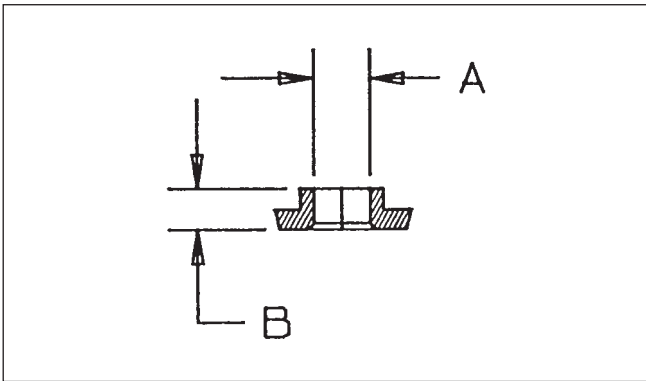

### Information needed:

- I.D. and height or screw size
- Material thickness and type
- Form-up or form-down
- Machine model

Extrusion tools are used in a broad spectrum of applications from self-tapping screws to cooling tube holders to air flow applications. As good as the result can be with extrusion tools, they are one of the trickiest of all tools. Depending on the height of the form, the material, and many other factors, the success and design of the tools can vary. That is why it is important for you to work with the experts at Wilson Tool so that we can help you get the desired results.

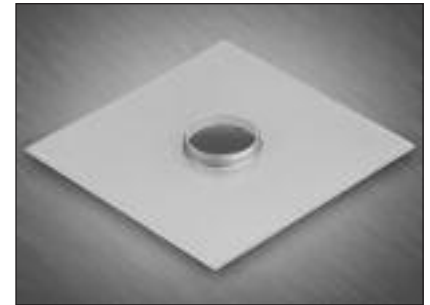

Tool Type	Description	For Extrusions (Inside Diameter)	Cat. No.
Size II	Form-Up Extrusion Tool with Urethane Punch Stripper†	Up to 15mm	25144
Size II	Form-Up Extrusion Tool with Metal Punch Ejector	Up to 15mm	25467
Size II	Form-Up Extrusion Tool with Metal Punch Ejector	15.01 to 30mm	25438
Size II	Form-Down Extrusion Tool	Up to 12mm	25707

† Minimum Centres:

Up to 7.51mm (outside diameter) extrusion - min 20mm centres - (If centres closer than 20mm, use Cat. No. 25467)

Over 7.51mm (outside diameter) extrusion - min 25mm centres - (If centres closer than 25mm, use Cat. No. 25467)

### Design criteria:

- Consult Sales Desk for size and height-restrictions per station.
- All extrusions must form a minimum of two material thicknesses overall.
- All form-up extrusions must be prepunched.
- The prepunched hole controls the height.
- A two gauge range of material is possible in mild steel and aluminium.
- All tools come with collar as standard.
- Tolerance required on I.D. greater than 6.0mm "A" dimension.
- Never use thicker material than the extrusion was designed for.
- 9.5mm diameter or less extrusions in 2.0mm or thicker stainless steel will not work.
- All tools come with optima coating as standard.
- Optilube coating recommended for extrusions in stainless steel.



### Information needed:

- Machine model
- Pipe size or actual diameter
- Material thickness and type
- Form-up or form-down
- Specify Standard or Special tab location and size

The Wilson Tool design of the Electrical Knockout (EKO) has full stripping in both upper and lower units, just where it is needed to produce good quality, reliable knockouts. It is possible to produce an EKO larger than the size range. Please consult our Sales Desk with details of your application.

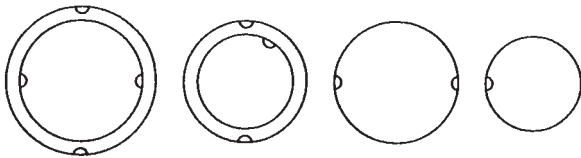

RECOMMENDED TAB LOCATIONS

Tool Type	Description	Cat. No.
Size II	Form-Up Round Single 6 – 20mm Ø	25522
Size II	Form-Up Round Single 20.01 – 40mm Ø	25111
Size II	Form-Up Round Single 40.01 – 50mm Ø	25594
Size II	Form-Up Round Single 50.01 – 60mm Ø	25595
Size II	Form-Down Round Single 15 – 35mm Ø	25403
Size II	Form-Down Round Single 35.1 – 56mm Ø	25460
Size II	Form-Up Shape Single	25189
Size II	Form-Up Round Double	25172

### Design criteria:

- EKO's are made to form one material thickness.
- You can get a good looking EKO with a 2 gauge range.
- Too much clearance will cause a burr.
- If you have a stripping problem, check height adjustment to be sure you are not over- or under-stroking.
- Consult Sales Desk for maximum sizes.



These Wilson Tool designed louvres have built-in stripping in the lower unit for trouble-free sheet travel and simple programming. They have a replaceable cutting blade and pocket insert in the upper unit and a replaceable forming insert in the lower unit. This enables cost-effective refurbishment.

All louvre tools use keyed collars (supplied with the tool).  
Relief is included in the price.

### Information needed:

- Machine model
- A, B, C, D and E dimensions
- Material thickness and type

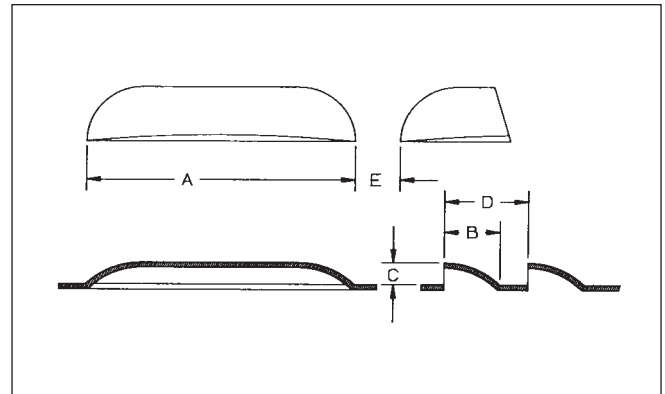

Tool Type	Standard description				Cat. No.
	A	B	C	D	
Size II	60mm	12mm	5mm	20mm	25130
Size III	90mm	15mm	7mm	25mm	25308

### REPLACEMENT PARTS

Tool Type	Description	Cat. No.
Size II	Cutting Blade	N/A
Size II	Forming Insert	N/A
Size II	Pocket Insert	N/A
Size III	Cutting Blade	N/A
Size III	Forming Insert	N/A
Size III	Pocket Insert	N/A



Standard sizes have Optima™ coated cutting and forming inserts.

### Design limitations:

- Maximum width louvre on our standard design is 12mm. We can make special louvres that are wider (P.O.A.)
- The higher the form the more noticeable the "drawing back" of the material will occur in the middle of the louvre.
- Multiple hits with a single hit louvre to produce a longer louvre cannot be done. Bad distortion of the louvre occurs. See progressive style.
- Maximum material thickness for single hit louvres for our standard design is 3.0mm mild steel. Louvres for thicker material (P.O.A.)
- Stainless steel may cause a burr on the top edge of the louvre. We can compensate for this but in some cases it cannot be eliminated completely.
- Sharpening is best left to the factory unless you have a tool and die shop with form-grinding equipment. Our turnaround time is within four days.



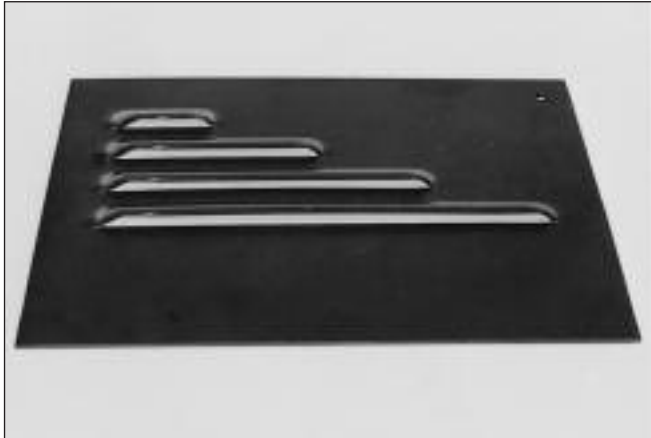

Now you can produce a louvre of any length! These Wilson Tool designed louvres have a replaceable cutting blade in the upper unit and a replaceable forming insert in the lower unit for cost-effective refurbishment.

The progressive louvre tool for Group S machines is made with an integral collar.

The progressive louvre tool for size 2 is made with a keyed collar (supplied with tool).

### Information needed:

- Machine model
- Material thickness and type
- B, C and D dimensions

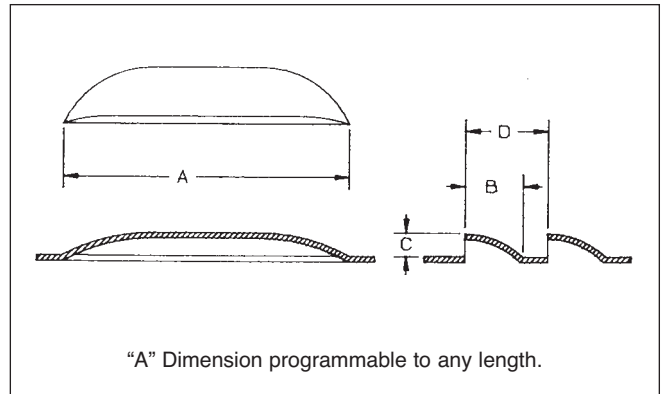

### STANDARD SIZE

Tool Type	Dimensions			Cat. No.
	B	C	D	
Size II	12mm	5mm	20mm	25170

Form length on first hit is 24mm long.

### REPLACEMENT PARTS

Tool Type	Description	Cat. No.
Size II	Cutting Blade	N/A
Size II	Forming Insert	N/A

Standard sizes have Optima™ coated cutting and forming inserts.

### Design criteria:

- Progressive louvres cannot be put back-to-back. The minimum web between louvres must be 2 material thicknesses. The closer the louvres, the greater the distortion.
- The ends of the progressive louvre blend out into the sheet.
- Maximum material thickness for aluminium or mild steel is 3.0mm.
- Maximum material thickness for stainless steel is 2.5mm.
- Minimum incremental moves are recommended.
- For non-standard sizes consult the Sales Desk for pricing.



These louvres have a replacement forming blade in the upper unit and a replacement forming insert in the lower unit for cost-effective refurbishment.

As this tool is form-down there is restriction in sheet movement.

### Information needed:

- Machine model
- Form-up and form-down
- A, B, C, D and E dimensions
- Material thickness and type

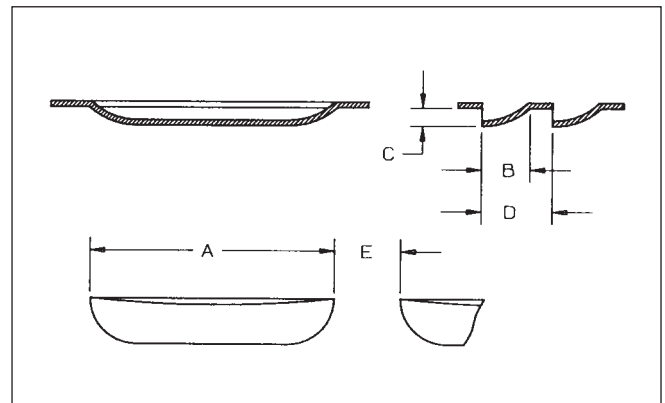

Tool Type	Standard description				Cat. No.
	A	B	C	D	
Size II	60mm	12mm	5mm	20mm	25651
Size III	90mm	15mm	7mm	25mm	25652

### REPLACEMENT PARTS

Tool Type	Description	Cat. No.
Size II	Cutting Blade	N/A
Size II	Forming Insert	N/A
Size III	Cutting Blade	N/A
Size III	Forming Insert	N/A

Standard sizes have Optima™ coated cutting and forming inserts.

### Design limitations:

- 0 and 90° is standard keying
- Maximum material 3.0mm mild steel
- For non-standard sizes consult Sales Desk



The bridge-type lance and form has a multitude of uses such as for shear stops, locators, dividers, card guides, ventilation, wire conduit or for wire tie-downs. When being used as a shear stop it does have the advantage of having a higher form so that it is easier to pick up gauging on.

The Wilson design gives a positive form which ensures a high quality part. The tools can be designed for either form-up or form-down operations.

All bridge lance and forms have integral collars.

### Information needed:

- Length, width, height and form of bridge
- Material thickness and type
- Station size
- Clearance
- Machine model



## WITH STRIPPING

	Cat. No.	Cat. No.	Cat. No.
	Size I	Size II	Size III
Single Bridge Form-Up	25146	25114	25635
Double Bridge Form-Up	25636	25075	25637

## WITHOUT STRIPPING IN UPPER UNIT (must be pre-pierced)

	Cat. No.	Cat. No.	Cat. No.
	Size I	Size II	Size III
Single Bridge Form-Up	25638	25196	25639

### Design limitations:

- Bridge Lance and Forms are made for a specific material thickness. You can punch thinner material (the form will change) but never thicker material.
- The width of the bridge should be 1½ times the material thickness in mild steel and aluminium and 2 times material thickness in stainless steel to warranty the tool.
- Form-Down Bridge Lance and Forms available, price upon request.
- Optional lead-in on Double Bridge P.O.A.



### Information needed:

- Drawing of card guide desired and centre-to-centre location
- Material thickness and type
- Prepunch shape: rectangle, obround or rectangle with radiused corners
- Machine model

Wilson Tool card guides are the result of years of development and engineering design changes.

Card guide tools may appear an expensive investment on the face of it, but vast savings can be made over other methods of inserting guides, such as plastic inserts. Taking all the costs of extra material-handling involved with secondary operations into account, these are very cost-effective tools.

Card guide tools have an integral collar for accurate punch assembly alignment.

Relief is already included in the price.

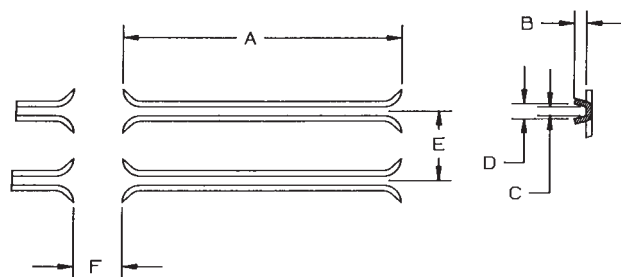

Tool Type	Description	Cat. No.
Size II	Max. 50mm	25402
Size II	Max. 70mm with modified cartridge	25119
Size III	Details on application	N/A

### Design criteria:

- There is a minimum height limitation on all card guides. Card guides with a height of less than 2.3mm from top of sheet to top of form will have a tendency to twist. (One side will form higher than the other.)
- Multiple hits to make a longer card guide will cause distortion.
- Wilson Tool will estimate the web of material to be formed.

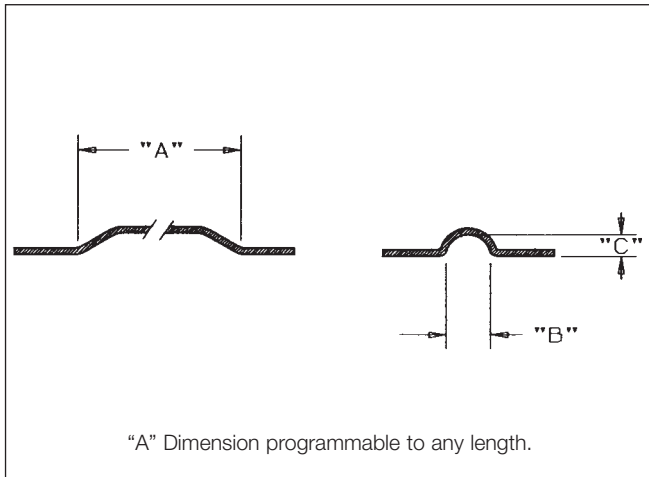

### Information needed:

- B and C dimensions
- Material thickness and type
- Machine model

First we introduced the progressive louvre, now Wilson Tool is offering you the progressive stiffening rib. This tool provides you with the ability to make high quality stiffening ribs right on the press, thus eliminating the time and cost of secondary operations.



Tool Type	Description	Cat. No.
Size II	Form-Up Progressive Rib for Straight Lines, with stripping in die*	25708
Size II	Form-Up Progressive Rib for Curved Lines, with stripping in die*	25425
Size II	Form-Up Progressive Rib for Straight Lines, without stripping in die*	26646
Size II	Form-Up Progressive Rib for Curved Lines, without stripping in die*	25156
Size II	Form-Up Rapid Progressive Rib, with stripping in die†	25708

\* Progressive rib tools are used to nibble the form in 0.5mm increments.

† Rapid progressive rib tool is used in 20mm increments.

Rib tools use a standard collar (not supplied with tool).

### Design criteria:

- "B" dimension must be a minimum of 2 times the "C" dimension.
- Maximum material thickness in mild steel is 2.5mm and stainless steel is 2.0mm.
- Minimum increment moves are recommended.
- Progressive ribs are made for a specific material thickness.
- A slight deformation will occur on the first hit.
- Ends of the rib flow back down into the material (not a distinct radius).

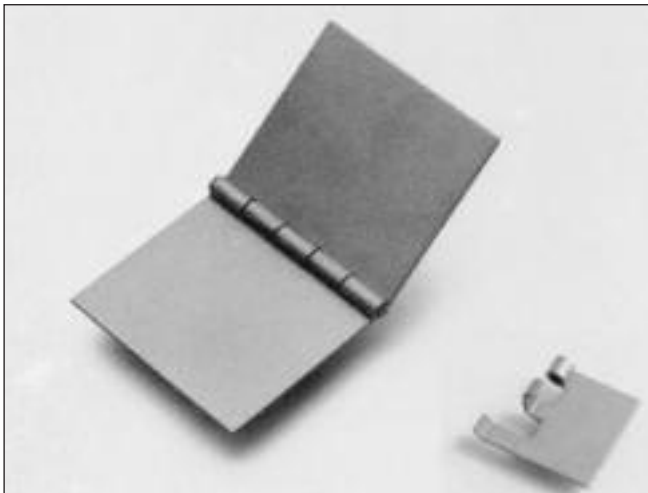

### Information needed:

- Drawing required of application
- Pin size and tolerance (B)
- Machine model
- Knuckle size (C)
- Material thickness and type
- Location of hinge on sheet required (edge or middle)

The Hinge Tool is a tool that eliminates costly hardware, fitting and lineup assembly. The Hinge Tool allows you to fabricate complete panels with their own integrated hinges. It consists of a set of two tools. The first tool makes two hits and the second tool, one hit. The net result is a fully curled "knuckle". Currently, our standard design is for a 3.0mm pin in 1.6mm material. Don't let this stop you. Call or fax us with your particular requirements. If you would like to see a sample of this technology, please let us know and we will arrange it.

Hinge tools are made with integral collars for accurate punch alignment.

Relief is included in the price.

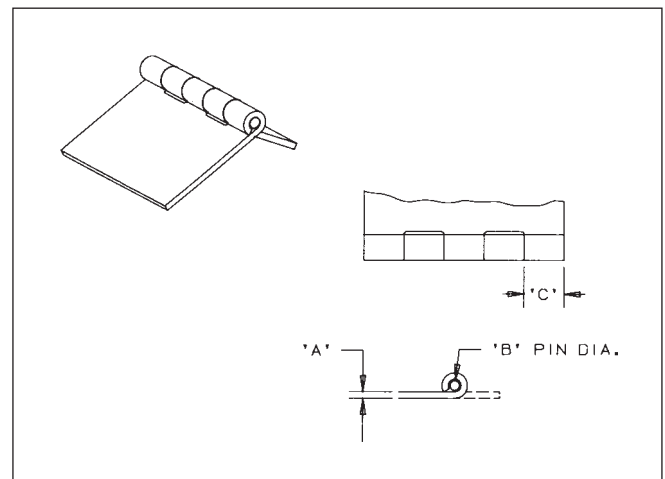

Tool Type	Description	Cat. No.
Size II	First tool (2 hits/Form)	25116
Size II	Second tool (1 hit/Curl)	25117

### Design criteria:

- All hinge tools for stainless steel must be checked out by Wilson Tool Engineering.
- Operating instructions will be sent with tools when shipped.
- Maximum material and pin size may vary according to machine, consult Sales Desk for limitations.
- Offset hinge tools available, price on application.
- The pre-punch varies when producing the hinge in middle of sheet.

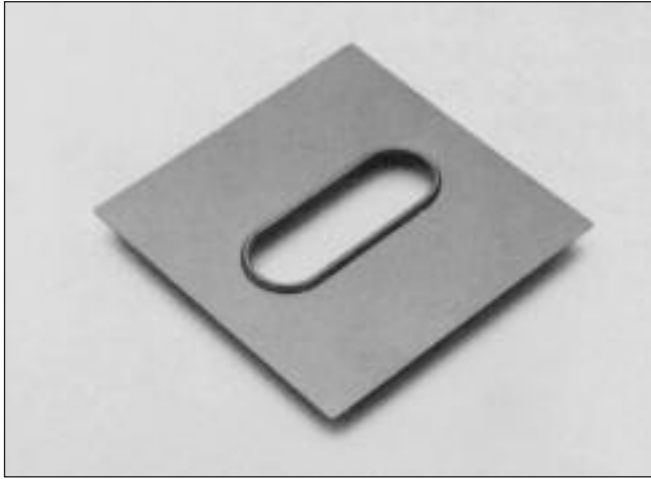

### Information needed:

- Drawing required of application
- Machine model
- Material thickness and type

The hand hold or rolover tool can be used in many applications. Rolling the material over creates a virtually burr-free opening, which lends itself nicely to hand holds, wire feed openings, grommets, and other special applications. There are three operations necessary to achieve the finished outcome. **FIRSTLY**, a prepunch hole is needed to create an opening. **SECONDLY**, an extrusion of material upward. **THIRDLY**, to curl the extruded opening downward. The amount of curl can be controlled by adjusting the length of the punch. The hand hold/rolover tool was developed to reduce costly secondary operations and handling.

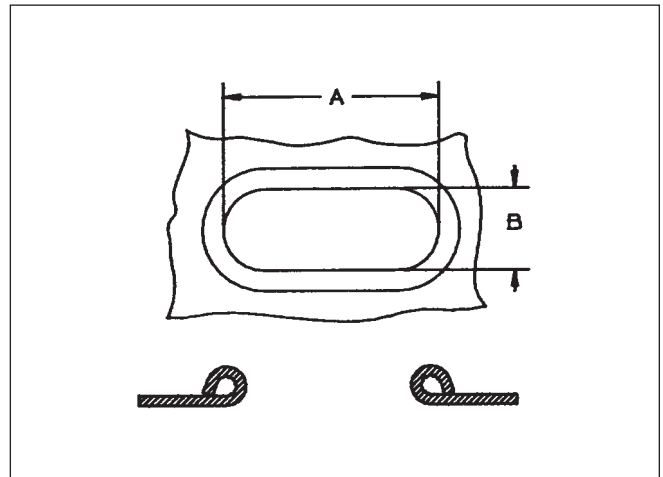

Tool Type	Description	Cat. No.
Size II	Extrusion (2nd hit)	N/A
Size II	Rollover (3rd hit)	N/A

For the prepunch operation use standard round or shaped set price from standards catalogue. (1st hit).

### Design criteria:

- Consult Sales Desk for size limitations.
- Pre-punch hole determined by Wilson Tool.
- For diameters or widths under 16.0mm, tearing may occur.

When you have varying applications of letter stamping you may want to consider a dash tool to give you greater flexibility in programming your own letter or number sizes. A tool similar to Figure 1 may be indexed to either 0°, 45°, 90° or 135° and with some clever programming will give you every digitized number and letter of the alphabet. For example.

1 2 3 or A B C

This tool is especially useful in applications where the number or letter of the part being marked is constantly changing or progressive.

**Information needed:**

- Material thickness and type
- Length of dash
- Machine model

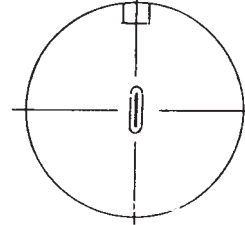

(Fig. 1)

Tool Type	Description	Cat. No.
Size I	Form-Down Dash Tool	25410
Size I	Form-Up Dash Tool	25427
Size II	Form-Down Dash Tool	25630

With rotation machines, only one tool is necessary.



## Earth Symbol

The earth symbol is a widely-used marking symbol in the electrical industry. It is both seen with a circle around the symbol and without. (See Fig. 2 and Fig. 3).

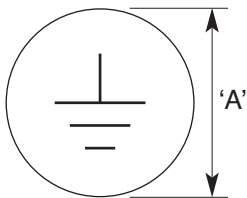

(Fig. 2)



(Fig. 3)

Earth Symbol tools are available as standard with dimension 'A' = 6mm, 8mm, 10mm, 12mm, 16mm, 20mm and 25mm



Tool Type	Description	Cat. No.
Size I	Form-Down Earth Symbol with Circle (standard dimensions)	25648
Size I	Form-Down Earth Symbol without Circle (standard dimensions)	25649
	Form-Up Earth Symbol with Circle (standard dimensions)	25709
	Form-Up Earth Symbol without Circle (standard dimensions)	25710
	Form-Up and Form-Down (in one hit) Earth Symbol with Circle (standard dimensions)	25711
	Form-Up and Form-Down (in one hit) Earth Symbol without Circle (standard dimensions)	25712

Standard Dimensions = ø 6mm, ø 8mm, ø 10mm, ø 12mm, ø 16mm, ø 20mm, ø 25mm





Marking material with letters or numbers is simple with Wilson Tool-designed stamping or forming tools. We can make virtually any design required, the only limitation is on size and depth which affects the tonnage required of the machine. There are various types of tool available.

### LETTER/NUMBER STAMP TOOL

Description	Cat.No.
Form-Down Letter Stamp – Single Row	25419
Form-Down Letter Stamp – Double Row	25211
Form-Up Letter Stamp – Single Row	25420
Form-Up Letter Stamp – Double Row	25210

Multiple rows available on request.

### Coined stamping tool

The stamping tool forms the number or letter within the material thickness only. In a typical form-down tool, the die would be a solid blank (no hole) to act as an anvil.

This type of tool is ideal for part numbers etc.

### Formed stamping tool

The forming tool actually bends or forms the material. In a form-down tool, the die would have the shape, plus clearance eroded to take the punch, as shown above.

This type is usually necessary if the area of the “coined” stamp is such that it exceeds the tonnage of the machine.

### Information needed:

- Material thickness
- Form-down or form-up
- Layout or artwork
- Machine model



The logo has found many uses from making a company’s name on a part for vendor identification, for cosmetic reasons or for marking particular symbols, such as the earth symbol in electrical applications (see over). Review your current application, and you may find many unique uses for these tools. Logo tools give your product a nice distinctive touch.

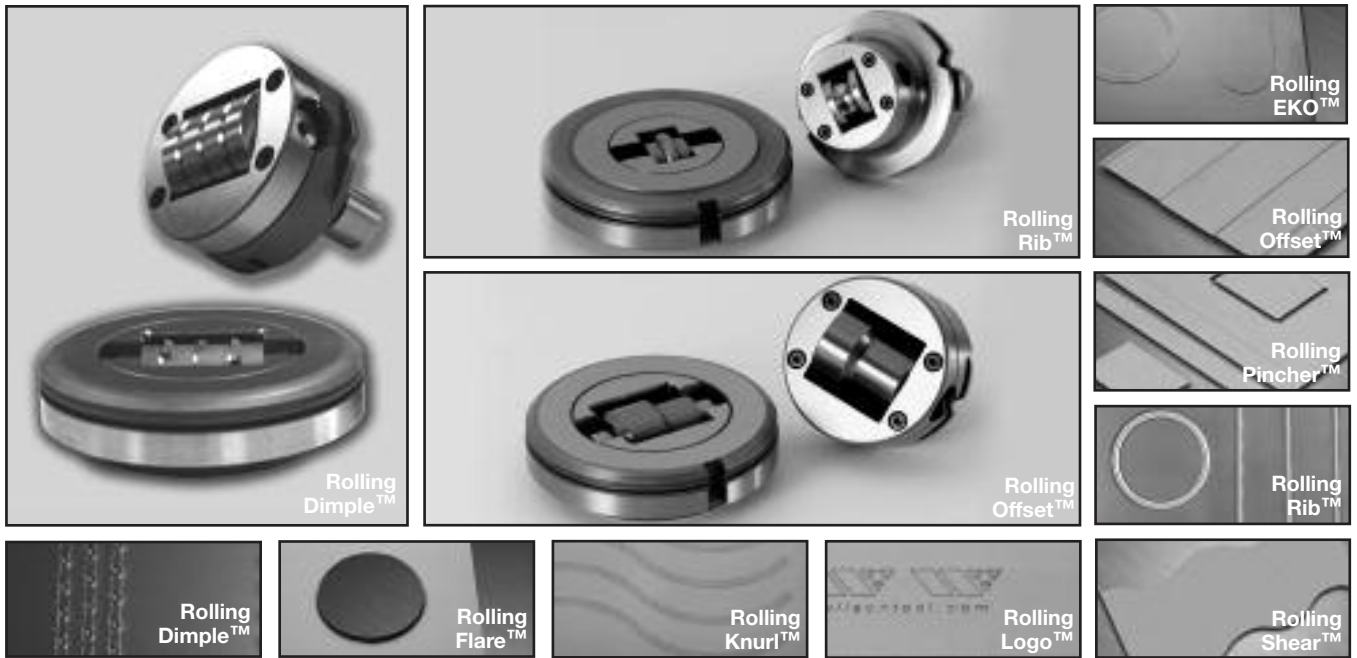

## Benefits

- High speed – up to programmed table travel speed
- Create lines, curves and circles
- Virtually no burrs or nibble marks on the sheet
- Eliminate scrap with the rolling shear and pincher
- Replacement forming wheels available
- Available in form-up or form-down (Rib and Offset only)
- Work on a wide range of material
- Wheel tools can start or end anywhere on the sheet
- Stock sizes available for fast delivery
- A complete instruction manual is sent with each tool
- Rolling Rib and Offset oversize design can be used with much thicker metal, up to 3mm in aluminium, stainless steel and mild steel (using oversize only)

## Considerations

- A programmable hydraulic ram or servo is required to use wheel technology
- Consult the Sales Desk for machine specific requirements
- Consult Sales Desk for the correct adapters when using tool in a Pullmax machine
- Consult Sales Desk for minimum radius of each tool
- Can be used on Pullmax machines and some others – please consult Sales Desk
- For Trumpf machines please consult Sales Desk

## Information needed

- Machine model
- Material thickness and type
- Artwork required for the Rolling Logo

Tool Type	Description	Cat. No.
Size II	Rolling Dimple	26374
Size II	Rolling EKO	26302
	Up to 1.6mm Over 1.6mm	26303
Size II	Rolling Flare	26305
Size II	Rolling Knurl Top of Sheet	26299
Size II	Rolling Logo	26308
Size II	Rolling Offset	
	1.6mm High	25570
	3.2mm High	25557
	Up to 4.75mm High Oversize (extra wide wheels)	26087 26337
Size II	Rolling Shear	
	Up to 1.6mm Over 1.6mm	25405 25563
Size II	Rolling Pincher	25559
Size II	Rolling Rib	
	2.4mm High	25405
	3.2mm High Oversize (extra wide wheels)	25561 26334

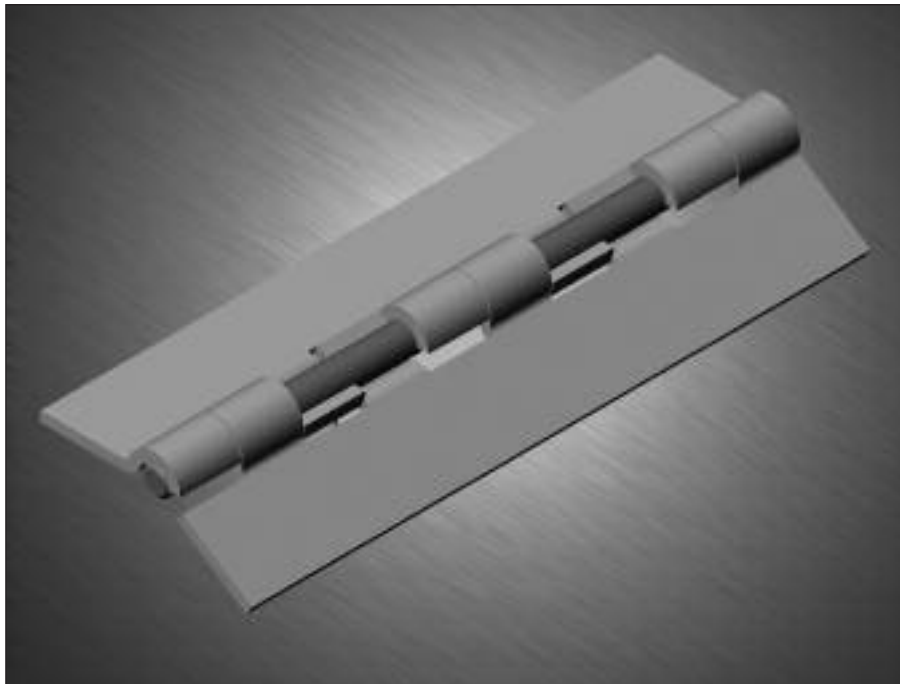

### Information needed

- Drawing required of application
- Pin size and tolerance
- Machine model
- Material thickness and type

The One Hit Hinge Tool produces strong, functional hinges in just one hit with one tool. One Hit Hinge Tools can be produced to suit a wide range of material types and pin diameters.

Unlike conventional hinge tools, the One Hit Hinge Tool can be used with plastic coated materials.

Tool Type	Description	Cat. No.
Size II	3-Knuckle	26261
Size II	5-Knuckle	26262

### Design criteria:

- Operating instructions will be sent with the tool when shipped.
- An individual study will be carried out by Wilson Tool to determine if your application is suited to a One Hit Hinge.



### Information needed

- Machine model
- Material thickness and type
- Dimensions as per page 23 (Louvre) or 27 (Card Guide).

Extend the maximum size of forms possible in Trumpf-Style tooling. The tools extend current boundaries of forms size by 25mm or more allowing users to produce larger louvers, lance & forms and card guides.

A-Plus Series™ Louvre tool extends sizes from 76mm to 102mm.

A-Plus Series™ Lance & Form tool extends sizes from 63mm to 89mm.

A-Plus Series™ Card Guide extends sizes from 71mm to 87mm.

### Design Criteria

- Special cartridge required with this range of tools (only available from Wilson Tool)



When a hole larger than the capacity of a single station on a machine is required, rotation machine-users are offered three options from Wilson Tool. All three operations give good quality holes, free from any scallop marks associated with a nibbled hole using a round punch.

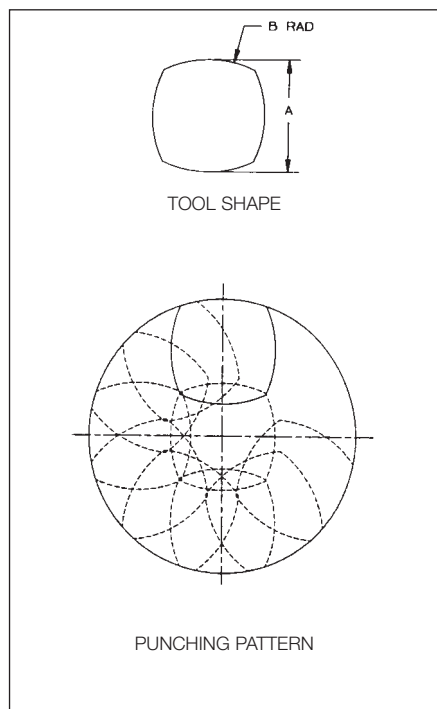

Figure 1

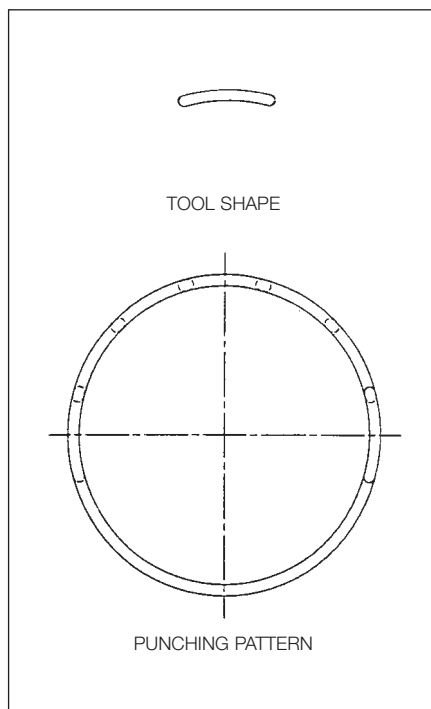

Figure 2

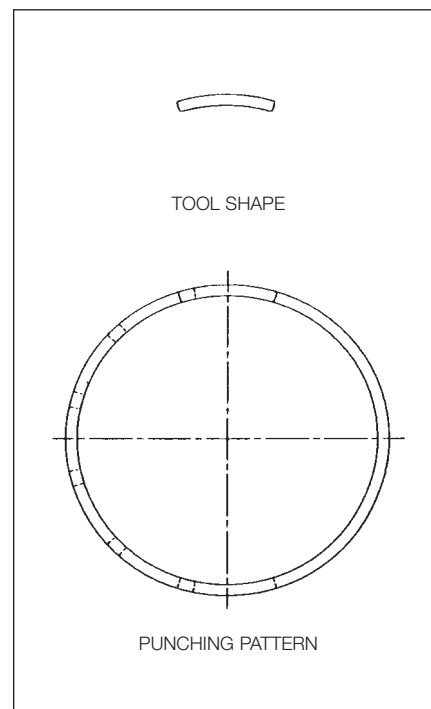
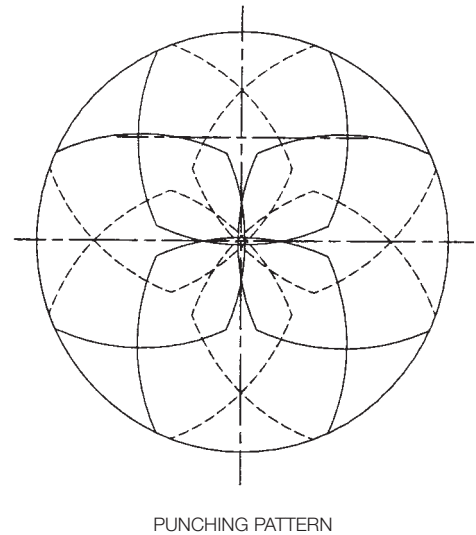
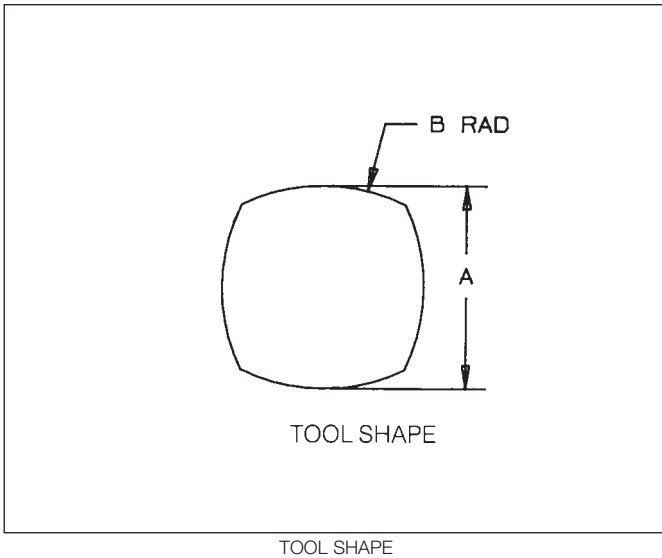

Figure 3

**Figure 1:** This tool is designed so that all the scrap material is removed through the die, thus eliminating the need to stop the machine to remove waste material. You may have FOUR different radii with this tool.

**Figure 2:** This type of tool is used by slitting around the diameter required and removing the material at the centre. The advantages with this design are, that fewer hits are required, you may punch round blanks, using the inside radius, or round holes, using the outside (or both!!)

**Figure 3:** This design is for use as for Figure 2, but square ends, half circles, may be produced.



When trying to punch a larger hole than the diameter of the largest station in the machine, our recommendation is a four-sided punch as shown above. The tool is designed so that each of the four faces is equivalent to 1/8 of the circle desired. The circle is then obtained by using the two punches, one keyed at 0° and the other at 45°, and making the four hits with each punch. (See punching pattern). Your hole is obtained with the minimum number of hits, produces no scallop, and as an extra bonus, the tool is designed so that no material is left to be removed from the centre of the circle.

Tool Type	Maximum Hole Obtained	Cat. No.
Size II	110.0mm dia	N/A
Size III	180.0mm dia	N/A

Programming details will be supplied with each tool.

# Conditions of Sale

## Order

Minimum order is £35.

## Credit

All orders accepted are subject to approval of our credit department. If you are a new account, please furnish us with a bank reference and three supplier references. A credit limit will be imposed on new accounts until credit has been established.

## Payment

Terms are net 30 days.

## Cancellation

In the event an order is cancelled, a charge will be made to cover labour, material and overheads.

## Claims

All claims for shortages must be made within 10 days of invoice date.

Prices are exclusive of V.A.T., but inclusive of packing and special delivery to your door. Tooling remains the property of Wilson Tool until full payment has been received.

# PRECISION TOOLING. UNBEATABLE PERFORMANCE.

For more than 40 years, Wilson Tool International® has provided industry-leading tooling solutions that enhance the performance of sheet metal fabricators.

The three divisions of Wilson Tool - Punch Press, Press Brake and Xtra - represent the most comprehensive line of tooling systems and accessories available. Our ability to consistently provide innovative, high quality products that outlast and outperform the competition is why the world's most successful fabricators rely upon Wilson Tool tooling systems.

A knowledgeable global sales force, multilingual customer support staff, same-day shipping and extensive distribution network are just a few of the benefits that keep our customers coming back time and again.

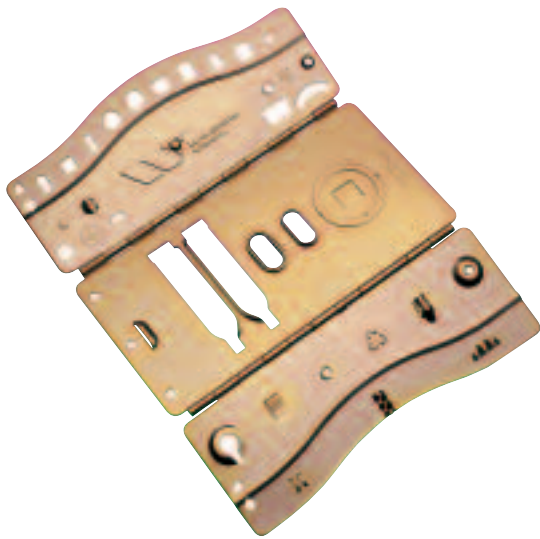

WILSON TOOL INTERNATIONAL

## WILSON TOOL INTERNATIONAL

### European Headquarters United Kingdom

Stirling Road, South Marston  
Industrial Estate, Swindon,  
Wiltshire, SN3 4TQ United Kingdom  
Press Brake: 0800 012 1475  
Tel: +44 (0) 1793 831818  
Fax: +44 (0) 1793 831945  
Email: [sales@wilsontool.eu.com](mailto:sales@wilsontool.eu.com)

### Worldwide Headquarters United States

12912 Farnham Avenue  
White Bear Lake, MN 55110 USA  
Tel: (651) 286 6001  
Fax: (651) 286 5959  
Email: [marketing@wilsontool.com](mailto:marketing@wilsontool.com)

### France

Bât B  
51 Rue D'Ourdy  
77550 Réau, France  
Tel: +33 (0) 164 13 47 80  
Fax: +33 (0) 164 13 47 81  
Email: [ventes@wilsontool.eu.com](mailto:ventes@wilsontool.eu.com)

### Germany

Gottlieb Daimler Str 2  
31552 Rodenberg, Germany  
Tel: +49 5723 747 0  
Fax: +49 5723 747 10  
Email: [verkauf@wilsontool.eu.com](mailto:verkauf@wilsontool.eu.com)

### Scandinavia

Islevdalvej 100  
DK-2610, Rodovre, Denmark  
Tel: +45 44 53 16 99  
Fax: +45 44 53 06 07  
Email: [sales@wilsontool.dk](mailto:sales@wilsontool.dk)

### China

No. 6 Building of 58  
4018 Lane Huaning Road  
Xinzhuan Industry Park  
201108 Shanghai, China  
Tel: +86 21 51089638  
Fax: +86 21 64422195  
Email: [sales@wilsontool.cn](mailto:sales@wilsontool.cn)

email:  
[sales@wilsontool.eu.com](mailto:sales@wilsontool.eu.com)  
Visit us online at:  
[www.wilsontool.com](http://www.wilsontool.com)